

Domestic Inbound Routing Guide to Morelos Warehouse



This routing guide applies to freight moving on Avnet's account & shipping directly to the following address:

Avnet

6700 W. Morelos Place
Chandler, AZ 85226

< 150 lbs. non-palletized: UPS

> 150 lbs. and/or palletized: Use map on page 3 to determine appropriate carrier

LTL: FedEx Freight, Mach1 / **Full truckload:** SWIFT

*For shipments of **8 pallets** or more, contact transportation-operations@avnet.com for carrier determination/approval*

Carrier Details:

All direct shipments to an Avnet facility where Avnet is paying the freight charges should be shipped using one of the carriers listed below:

Shipments weighing

1 to 150 lbs.

151 to 7,000 lbs. (or palletized)

Carrier

UPS Ground (Bill Recipient - see page 2)

Refer to map for carrier assignments (see page 3)

FedEx Freight (see page 4)

Mach1 (Collect - see page 5)

If there are multiple small boxes that exceed 151 lbs. total going to the same Avnet location, they must be palletized and shipped via the appropriate carrier. Should this requirement be violated excessive charges may be debited to your account.

8,000 lbs. and greater

Shipments exceeding 8,000 lbs. of chargeable weight or 10 pallets:

Contact the Avnet transportation team at transportation-operations@avnet.com

Domestic Inbound Routing Guide to Morelos Warehouse

UPS Express (Bill Receipt)

Since UPS offers a variety of ways to ship, the waybills will look slightly different; however, Avnet's PO number must be indicated in the reference field number. In this specific waybill the PO is indicated here.

UPS WORLDWIDE SERVICES WAYBILL (no-negotiable)

SHIPPER'S INFORMATION

SHIPPER'S UPS ACCOUNT NO. A SHIPPER'S IDENTIFICATION NO. FOR CUSTOMS PURPOSES (V.A.T. No., etc.) B
NAME OF SENDER C TELEPHONE NO. (VERY IMPORTANT) D
COMPANY NAME AND ADDRESS (Include Postal Code) E
POSTAL CODE F COUNTRY G

RECEIVER'S INFORMATION

RECEIVER'S UPS ACCOUNT NO. H RECEIVER'S IDENTIFICATION NO. FOR CUSTOMS PURPOSES (E.O.M., V.A.T., Importer's No., B.Z.C. No., etc.) I
NAME OF CONTACT PERSON J TELEPHONE NO. (VERY IMPORTANT) K
COMPANY NAME AND ADDRESS (Include Postal Code) L
POSTAL CODE M COUNTRY N

SHIPMENT INFORMATION

4 SERVICE LEVEL (Please mark large "X". Select one level only. Refer to the appropriate service guide for levels available.)
EXPRESS PLUS 1+
EXPRESS 1
EXPRESS SAVER 1P
EXPEDITED 2

5 SHIPMENT INFO
NO. OF ADDITIONAL HANDLING PACKAGES IN SHIPMENT
ENV 10KG BOX 25KG BOX OTHER
DESCRIPTION OF GOODS
INDICATE IF DOCUMENTS ONLY
Mark "X" if shipment contains documents of no commercial value

DECLARED VALUE OF SHIPMENT FOR CARRIAGE ONLY (Specify Currency) J AMOUNT CURRENCY K AMOUNT
DECLARED VALUE OF SHIPMENT FOR CUSTOMS ONLY (Specify Currency) L AMOUNT CURRENCY M AMOUNT

6 COUNTRY OF ORIGIN (MANUFACTURE) OF GOODS

7 DATE OF SHIPMENT SHIPPER'S SIGNATURE

RECEIVED FOR UPS BY: DATE: TIME:

SHIPPER'S COPY

PO number is indicated here

Domestic Inbound Routing Guide to Morelos Warehouse

Carrier Map

This map applies to shipments moving inbound to Arizona.

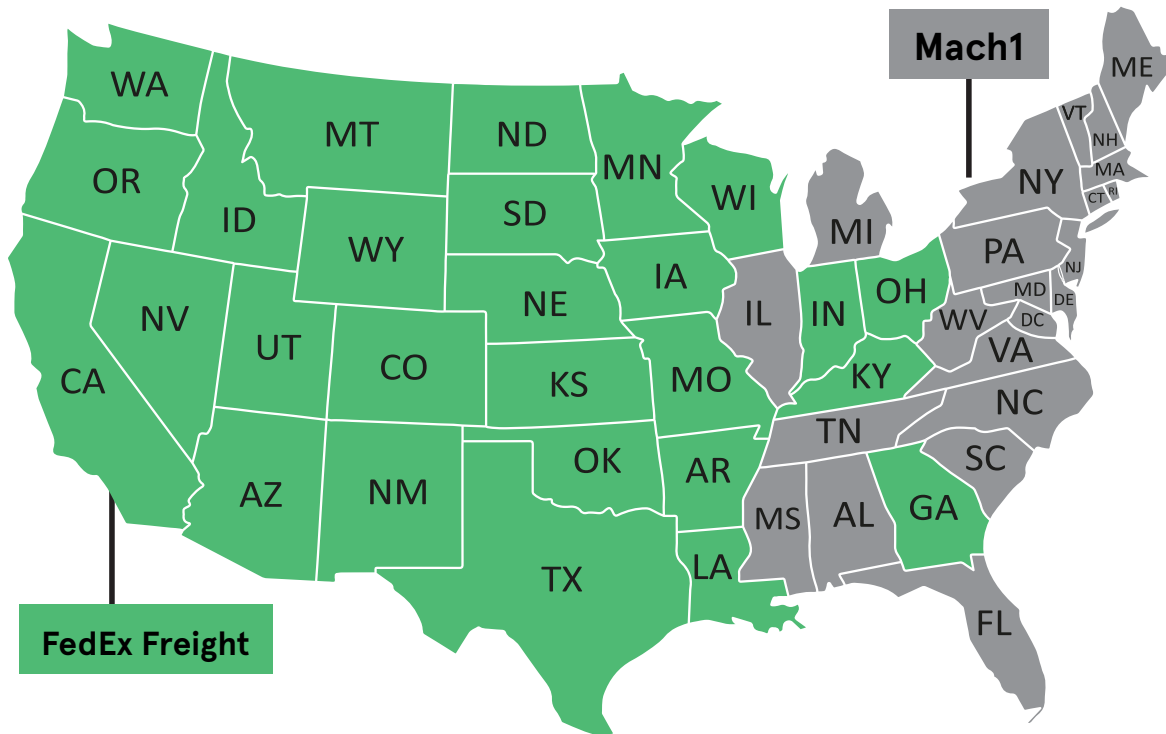

Avnet Preferred LTL/Freight Forwarders

FedEx Freight
Mach1

Full truckloads

SWIFT

Domestic Inbound Routing Guide to Morelos Warehouse

FedEx Freight (Collect or reference FedEx account **356789172**)

Please check FedEx Freight Economy when shipping product to Avnet
Call (866) 393-4585 to arrange a pick-up with FedEx Freight

PO number should be indicated here

UNIFORM STRAIGHT BILL OF LADING ORIGINAL---NOT NEGOTIABLE											
SUBJECT TO THE TERMS AND CONDITIONS OF THE UNIFORM BILL OF LADING --- QUESTIONS? CALL 1.866.393.4585											
 PLACE PRO LABEL HERE			Date		Purchase Order #						
			Shipper #		Shipper #						
			REQUIRED: Please select a service type <input type="checkbox"/> FedEx Freight® Priority (FXFE) <input type="checkbox"/> FedEx Freight® Economy (FXNL)			OPTIONAL: You may select a money-back guarantee delivery (charges and tariff limitations may apply). <input type="checkbox"/> A.M. Delivery <input type="checkbox"/> Close of Business Delivery					
SHIPPER (from)			Please provide ZIP codes and phone numbers.				CONSIGNEE (to)				
Shipper	FXF Acct. #		Consignee		FXF Acct. #						
Attn. to	Area Code	Phone Number	Attn. to		Area Code Phone Number						
Address			Address								
Address (Store, Dept., Ste., Fir., Apt., Div.)			Address (Store, Dept., Ste., Fir., Apt., Div.)								
Address			Address								
City			City								
State/Province			ZIP/Postal Code		Country			State/Province ZIP/Postal Code Country			
Accessorial Charges <input type="checkbox"/> Liftgate <input type="checkbox"/> Inside Pickup <input type="checkbox"/>			Accessorial Charges <input type="checkbox"/> Liftgate <input type="checkbox"/> Inside Pickup <input type="checkbox"/>								
Shipper Bill of Lading			Customer Delivery Window:								
Special Instruction											
BILL FREIGHT COLLECT (if different than shipper above):											
Name			Phone #		Mailing Address						
City			State		ZIP/Postal Code			Country Area Code Phone Number			
Freight charges are marked collect.			C.O.D.		1. The letters "C.O.D." must appear in box before consignee's name above. 2. C.O.D. funds to be collected as: <input type="checkbox"/> Certified Funds <input type="checkbox"/> Company Check <input type="checkbox"/> Personal Check 3. C.O.D. fee to be paid by: <input type="checkbox"/> Shipper <input type="checkbox"/> Consignee						
CHECK BOX IF COLLECT <input type="checkbox"/>			\$ AMOUNT								
REMIT C.O.D. TO (if different than shipper above):											
Name			Mailing Address								
City			State		ZIP/Postal Code			Country Code Area Code Phone Number			
<small>RECEIVED: Subject to individually determined rates or contracts that have been agreed upon in writing between the carrier and shipper, if applicable, otherwise to the rates, classifications and rules that have been established by the carrier and are available to the shipper, on request, and to all applicable state and federal regulations, the property described below, in apparent good order, except as noted (contents and condition of contents of packages unknown), marked, consigned and destined as shown hereon, which said carrier agrees to carry to destination, if on its route, or otherwise to deliver to another carrier on the route to destination. Every service to be performed hereunder shall be subject to all the conditions not prohibited by law, whether printed or written, herein contained, including the conditions on the back hereof, and the conditions of the FXF 100 Series Rules Tariff, or otherwise referenced, which are hereby agreed to by the shipper and accepted for himself and his assigns.</small>											
HANDLING UNITS (H/U)	H/U PKG. TYPE	PIECES	HM (X)	DESCRIPTION OF ARTICLES, KIND OF PACKAGE, SPECIAL MARKS AND EXCEPTIONS (subject to correction)				WEIGHT IN LBS.	NMFC ITEM # (subject to correction)	CLASS	CUBE (in cu ft)

Domestic Inbound Routing Guide to Morelos Warehouse

Mach1 (Collect)

Call (800) 553-7774 to arrange a pick-up with Mach1

MACH1
GLOBAL SERVICES, INC.

TARIFF REGULATIONS REQUIRE PAYMENT WITHIN 15 DAYS AND PROVIDE FOR A CHARGE OF 1 1/2% PER MONTH FOR LATE PAYMENT.

MACH 1 GLOBAL SERVICES, INC.
LOS ANGELES, CALIFORNIA • (877) 480-8224
F.M.C. LICENSE #4036NF FED. ID #86-0617458 AIRBILL NO.
www.mach1global.com SCAC: MOAV / MOAC

SHIPPER'S NO. CONSIGNEE'S NO.
FROM (SHIPPER) TO (CONSIGNEE)

BILL TO AVNET ENG
60 ... NCKE
C ... DLER Z ... 26
C ... MER SALES
ACC ... CODE

PREPAID COLLECT 3rd PART CASH

DECLARED VALUE \$

SEE RELEASE CLAUSE BELOW

REQUIRED SERVICE LEVELS NOTE: IF SERVICE DESCRIPTION IS NOT IDENTIFIED, MACH 1 WILL AUTOMATICALLY SHIP AS 2ND DAY SERVICE.

OVERNIGHT SERVICE 2ND DAY SERVICE 3-5 DAY SERVICE CHARTER
 TRUCK LOAD OCEAN OTHER (See Special Instructions)

NO. OF PCS/PKGS.	DESCRIPTION OF PIECES Nature of Contents, Marks and Numbers	GROSS WT. POUNDS	CHARGEABLE WEIGHT	ORIGIN CODE	DEST. CODE	CHARGES
						CHARGES
						PICKUP
						DELIVERY
NON-NEGOTIABLE WAYBILL SUBJECT TO CONDITIONS SET FORTH ON REVERSE SIDE.						EXCESS VALUE
WEIGHTS SUBJECT TO DIMENSIONAL CORRECTIONS			TOTAL DIMENSIONAL WEIGHT	UNLESS A GREATER VALUE IS DECLARED HEREIN, THE SHIPPER AGREES AND DECLARES THAT THE VALUE OF THE PROPERTY IS RELEASED TO AN AMOUNT NOT EXCEEDING \$50.00 OR 50¢ PER POUND PER PIECE WHICHEVER IS HIGHER.		PACKAGING/CRATING
PIECES	LENGTH	WIDTH	HEIGHT			OTHER
						C.O.D. FEE

AIRBILL NO. SPECIAL INSTRUCTIONS

I CERTIFY THAT THIS SHIPMENT DOES NOT CONTAIN ANY UNAUTHORIZED EXPLOSIVES, Destructive DEVICES OR HAZARDOUS MATERIALS. I CONSENT TO A SEARCH OF THIS SHIPMENT. I AM AWARE THAT THIS ENDORSEMENT AND ORIGINAL SIGNATURE ALONG WITH OTHER SHIPPING DOCUMENTS WILL BE RETAINED ON FILE UNTIL THE SHIPMENT IS DELIVERED.

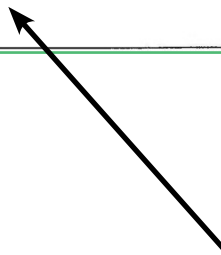

PO number is indicated here

Domestic Inbound Routing Guide to Morelos Warehouse

Bill of Lading and Routing Instructions:

1. Billed weight is determined by the greater weight; actual weight or dimensional weight.
2. **Should you have a shipment that is greater than 7,000 lbs. (either actual or dimensional) contact Avnet transportation for shipping instructions.**
3. Any shipment weighing less than 151 lbs. should be shipped via UPS (unless this shipment is palletized or has a value in excess of \$50,000.00). Should this requirement be violated, excessive charges may be debited to your account.
4. All shipments must move ground (transit time is 3-5 days) unless authorized by the materials department. If freight ships any other method other than ground without authorization from the above department it may result in excessive freight charges being debited to your account.
5. All shipments must be called in prior to 15:00. Should a carrier receive a pickup call after 15:00 additional charges may be debited to your account.
6. All shipments must be picked up prior to 17:00. Should a carrier need to make a late pickup additional charges may be debited to your account.
7. **Do not insure or declare a value unless specifically instructed to do so by Avnet.**
8. Please consolidate shipments for any one day on one Bill of Lading.
9. If the value of the shipment is greater than \$50,000.00 please ship this on the appropriate heavyweight carrier.
10. Indicate purchase order number(s) on packing sheets, Bill of Lading, Airbills or online system.
11. **Both pallet count and piece count must be indicated on Bill of Lading, Airbills or online system.**
12. Should you need an account number please contact the Avnet transportation department.
13. Any shipment sent collect with a non-authorized carrier will be charged back to the shipper.
14. Avnet requires a delivery appointment/notification 24 hours prior to delivery if shipping on a carrier not listed above. Please contact P140-Inbound@avnet.com to make arrangements.
15. Shipments greater than 150 lbs. or all palletized requiring overnight/premium or two day transit time should shipped via Expedito's Account# G0277170.

How to determine the total chargeable weight for ground shipments

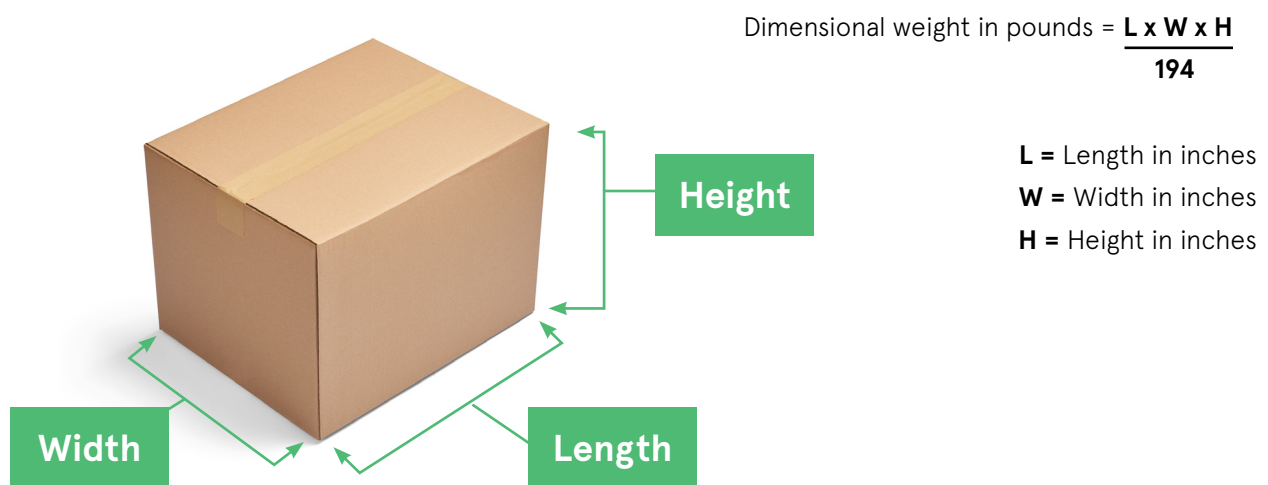

The instructions in this document supersede previous shipping instructions and are to be followed except when authorized by our Materials Department. Excessive freight charges due to shipments being tendered contrary to our instructions may be debited to your account.

Copyright © 2017 Avnet, Inc. AVNET, "Reach Further," and the AV logo are registered trademarks of Avnet, Inc. All other brands are the property of their respective owners. C1010r201703

Avnet
2211 S. 47th Street
Phoenix, AZ 85034
1-800-332-8638
avnet.com