

MaaXBoard OSM93 features an NXP i.MX 93 System on Chip compute module, with integrated AI/ML NPU accelerator, EdgeLock security enclave and Energy Flex architecture that supports separated processing domains, such as the Application domain with two Arm® Cortex®-A55 (1.7 GHz) cores, the real time domain with Arm® Cortex®-M33 (250 MHz) core and Flex domain with Arm® Ethos-U65 NPU (1 GHz). Other resources on the fitted MSC OSM-SF-IMX93 solder-down module include eMMC (16GB) memory, LPDDR4 (2GB, 3.7 GT/s) with inline ECC support, RTC clock and NXP PCA9451 PMIC.

The Raspberry Pi form-factor carrier SBC carrier board adds QSPI flash memory (16Mbit) plus connectivity and UI interfaces. High speed interfaces include four USB 2.0 interfaces (2x host type A, 1x host type-C, 1x device type-C), MIPI DSI display and MIPI CSI camera interfaces, two 1 Gbps Ethernet ports and two high-speed CAN interfaces. Expansion interfaces include a Pi-Hat 40pin-header, 6-pin ADC header and 6-pin SAI digital audio header (supplemented by two onboard PDM microphones). Level-shifted debug UARTs are pinned-out for the application and RT cores.

An M.2 key-E connector on back of the board facilitates easy integration of optional NXP based tri-radio M.2 module solutions, for concurrent Wi-Fi 6, Bluetooth (5.3) and 802.15.4 wireless operation.

Target apps

- Automotive Applications (Driver Monitoring System)
- Smart Home Automation
- Network Gateways
- Building control (HVAC, lighting)
- EV Charging
- Inventory and Asset Monitoring
- Smart City, Smart Camera Systems
- Vital Sign Monitoring
- Industrial & Contactless HMI

Markets

- Healthcare & Medical
- Home & Building Automation
- Industrial

Kit includes

- MaaXBoard OSM93 Board

Accessory options

- Wi-Fi 6, BT 5.3, 802.15.4 (M.2 wireless module)
- MIPI DSI Display (7" or 5")
- MIPI CSI Camera Modules

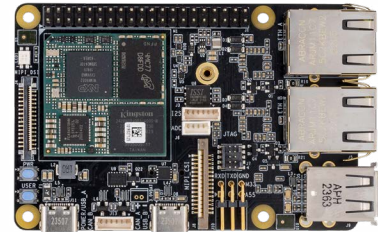

Features

NXP i.MX93 Processor

- 2x Arm Cortex-A55 (@ up to 1.7 GHz)
- 1x Arm Cortex-M33 (@ 250 MHz)
- 1x Arm Ethos-U65 NPU (@ 1 GHz / 0.5 TOPS)
- EdgeLock Secure Enclave

Memory

- 640 KB OCRAM w/ ECC
- 2 GB LPDDR4 SDRAM
- 16 GB eMMC 5.1 Flash
- 16 MB QSPI NOR Flash

Communication & User Interfaces

- 2x USB 2.0 Host (type A)
- 1x USB 2.0 Host (type C)
- MIPI DSI Interface (4L)
- MIPI CSI Camera Interface (2L)
- 2x 1 Gbps Ethernet (1x TSN)
- UART, SPI, I2C, I2S, GPIO interfaces

Expansion, Power, Mechanical

- 40-Pin Pi-HAT header
- 10-pin JTAG header
- 4-pin ADC header
- 6-pin CAN-FD header (incl. CAN transceivers)
- 2x3-pin Console Debug header
- 6-pin SAI Digital Audio header
- 2x PDM Microphone
- M.2 Connector: Wi-Fi 6/BT 5.3/802.15.4 option
- DC Power supply: 5V/3A USB-C Power Adapter
- Operating Temperature -40C..+85C
- Dimensions: 85mm x 56mm

Block diagram

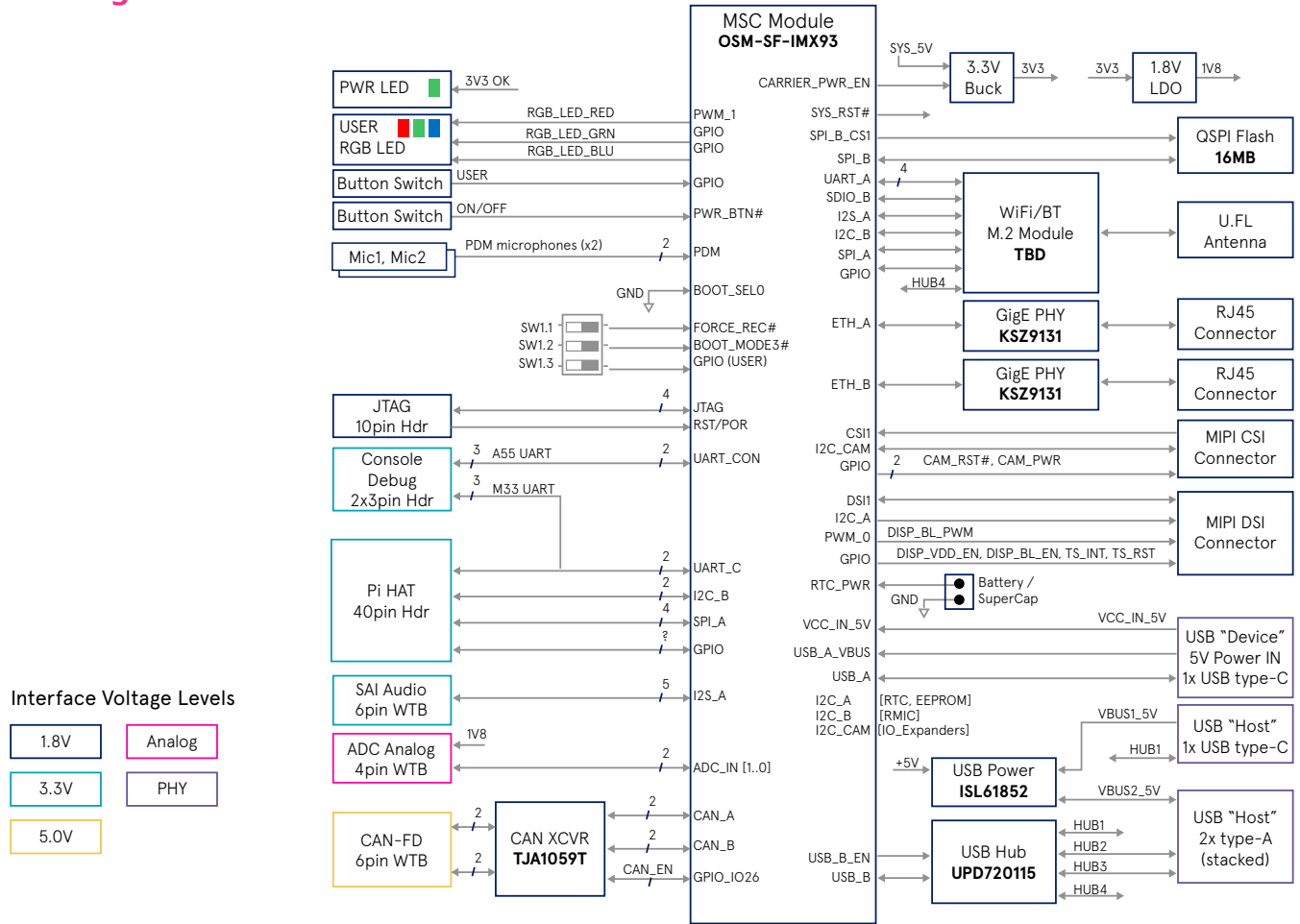

Featured manufacturers



Parts

Part number	Description	For more information
AES-MAAXB-OSM93-DK-G	MaaXBoard OSM93 Board	avnet.me/maaxboard-osm93

Related parts

Part number	Description	For more information
OSM-SF-IMX93	MSC OSM-SF-IMX93 (NXP i.MX93 Compute Module)	avnet.me/msc-osm93
OSM-SF-IMX91	MSC OSM-SF-IMX91 (NXP i.MX91 Compute Module)	avnet.me/msc-osm91
AES-ACC-DISP-5INCH	MaaXBoard 5-inch MIPI Touchscreen	Call for availability
AES-ACC-DISP-7INCH	MaaXBoard 7-inch MIPI Touchscreen	Call for availability

Regions available for purchase: Americas, EMEA

Global Headquarters

Tria Technologies | Industriestr. 16, 76297 Stutensee | tria-technologies.com

Worldwide Distributor: **Avnet**

Online sales: **Farnell**