



Timing Solutions for
MOBILE, IOT & CONSUMER

Extensive portfolio

Enables longer battery life

Ultra-small footprint

Better performance and higher stability in harsh environments

Programmable, instant samples, shorter lead time

A small part from
SiTime runs a big
part of your world

Ultra Stable Oscillators, TCXOs and DCXOs

Precision Timing uniquely enables electronics products that are smarter, faster, more reliable, smaller and lower power. SiTime MEMS-based oscillators for Mobile, IoT and Consumer markets are optimized for small size and low power while also providing excellent stability over temperature and in response to harsh environments including stress, vibration and rapid temperature changes often found in tightly confined devices such as wearables. These products offer excellent jitter performance and are designed to minimize EMI while driving multiple loads.

Application Circuits

- Local oscillator
- Reference clock
- Sleep clock
- GNSS holdover
- Dynamic frequency tuning (DCXO)



SMARTPHONE & MOBILE ACCESSORIES



SMART WATCH / FITNESS TRACKER

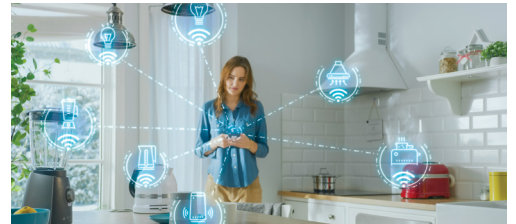

SMART HOME

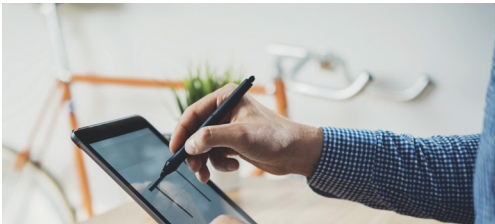

STYLUS & TABLET



SMART GLASSES / AR / VR

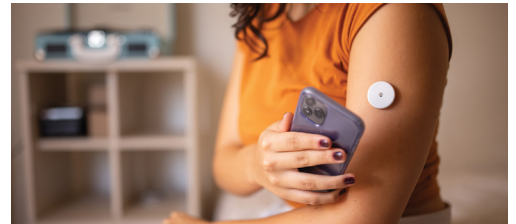

MEDICAL WEARABLES / INPLANTABLES



SCREENLESS AI ASSISTANTS

Size

- Smallest 32 kHz footprint in a 1.5 x 0.8 mm CSP; 80% smaller than quartz
- Oscillator output drives multiple loads and reduces component count

System performance

- Ultra stable over wide temperature ranges (down to ± 3 ppm)
- Ultra-low power < 1 μ A for 32 kHz
- Ultra-low RMS Period Jitter
- Wide range from 1 Hz to 125 MHz
- Programmable frequency eliminates NRE for custom parts

Power

- XO as low as 510 nA with ± 20 ppm (32 kHz)
- TCXO as low as 0.99 μ A at ± 5 ppm (32 kHz)
- 1.2 V to 3.63 V supported (product dependent)

Lower Power

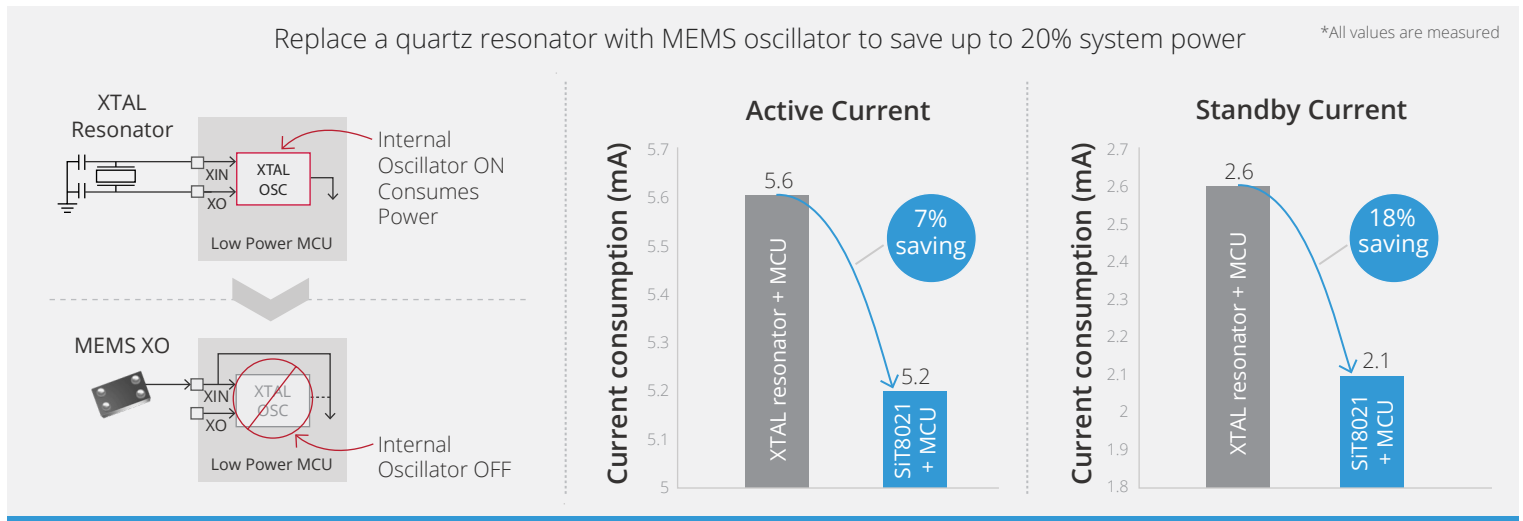

Smallest Size, Lower BOM

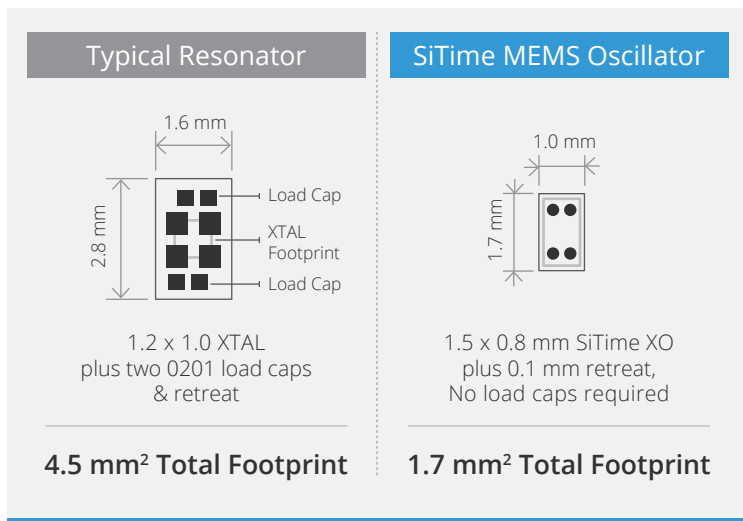

Best 32 kHz Stability

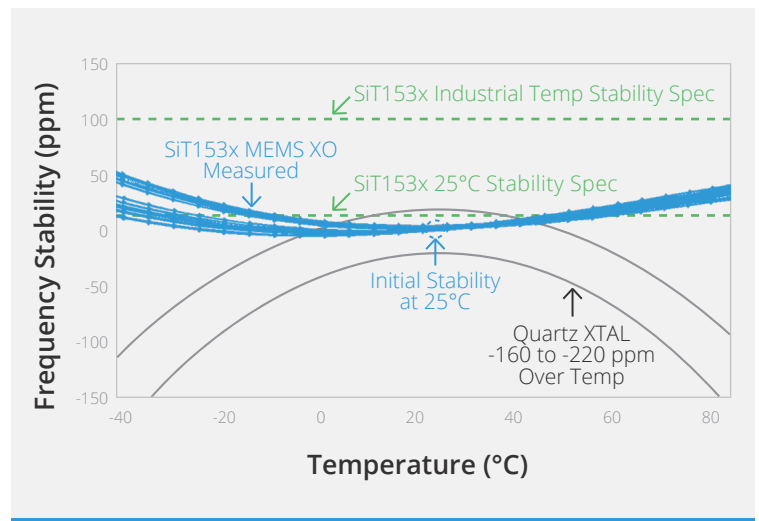

Drive Multiple Loads

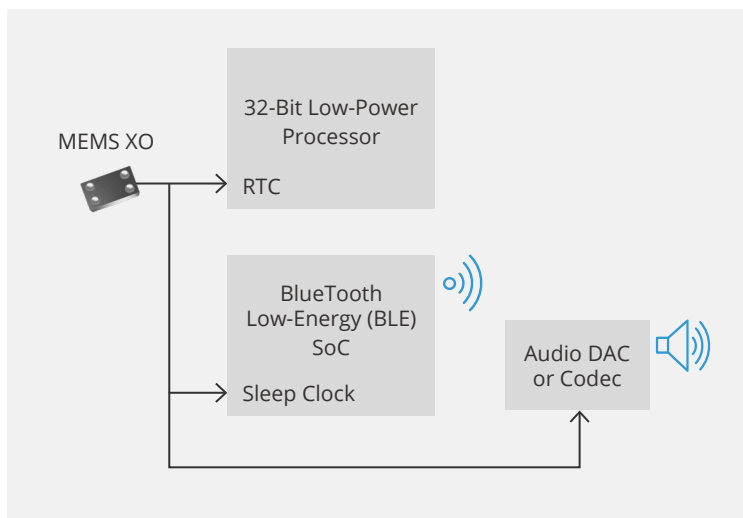

Low Power Feature

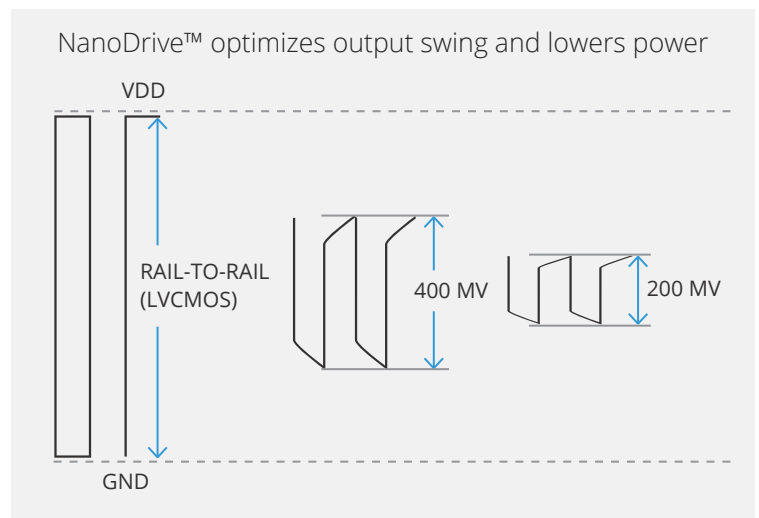

SiTime Base Part No.	Output Frequency	Frequency Stability (ppm)	Supply Volt. (V)	Supply Current (Typical)	RMS Period Jitter	Packages (mm x mm)	Output Logic	Features
----------------------	------------------	---------------------------	------------------	--------------------------	-------------------	--------------------	--------------	----------

μPOWER 32 kHz OSCILLATORS | Replace quartz XTAL/XO | Smallest size | Drive multiple loads | Higher accuracy | Better reliability

SiT1811	32.768 kHz	±20	1.35 to 1.98	510 nA	2.5 ns	1211	LVC MOS	Ultra-low power
SiT1532		75, 100, 250 over temp (10, 20 room temp)	1.2 to 3.63	0.90 μA	35 ns	1508	NanoDrive, LVC MOS	Low voltage, XTAL replacement
SiT1533						2012		
SiT1573		±100	1.62 to 3.63	4.0 μA	30 ns	1508	LVC MOS	Small size
SiT1581	1 Hz to 2.5 MHz	±50		4.5 μA	2.5 ns		LVC MOS	Immune to small-molecule gasses
SiT1630	32.768, 16.384 kHz	75, 100, 150 over temp (20 room temp)	1.5 to 3.63	1.0 μA	35 ns	2012, SOT23-5	LVC MOS	-40 to +105°C

μPOWER MHz OSCILLATORS | Smallest size | Lower power | Drive two or more loads | Higher accuracy | Programmable for design flexibility

SiT1534	1 Hz to 32.768 kHz	75, 100, 250 over temp (20 room temp)	1.2 to 3.63	0.90 μA (32 kHz)	35 ns (32 kHz)	1508, 2012	NanoDrive, LVC MOS	Low power
SiT1569	1 Hz to 462.5 kHz	±50	1.62 to 3.63	3.3 μA (100 kHz)	4 ns (100 kHz)	1508	LVC MOS	Low jitter
SiT1579	1 Hz to 2.5 MHz	±50	1.62 to 3.63	6.0 μA (100 kHz)	2.2 ns (100 kHz)			Low jitter
SiT1581	1 Hz to 2.5 MHz	±50	1.62 to 3.63	6.0 μA (100 kHz)	2.5 ns (32 kHz)			Immune to small-molecule gasses
SiT8021	1 MHz to 26 MHz	±50, ±100	1.8, 2.5 to 3.3	60 to 280 μA (0.7 μA stby)	75 ps (6.144 MHz)			Ultra-low power
SiT3901	2.6, 6.78, 13.56 MHz			105 μA (2.6 MHz), 220 μA (6.78 MHz)	80 ps (6.78 MHz)	Digitally Controlled Oscillator		
SiT1605 SiT1615	4 MHz to 125 MHz	±25, ±30, ±50	1.14 to 3.63	2.5 mA (27 MHz)	1 ps (27 MHz)	1612, 2016, 2520, 3225	LVC MOS	Immune to small-molecule gasses
SiT8008	1 MHz to 110 MHz	±20, ±25, ±50	1.62 to 3.63	3.7 mA (20 MHz)	1.8 ps (75 MHz)	2016, 2520, 3225, 5032, 7050	LVC MOS	Field programmable

μPOWER 32 kHz TCXOs | Replace quartz XTAL/TCXO | Smallest size | Drive two or more loads | Higher accuracy | Better reliability

SiT1552 TCXO	32.768 kHz	±10, ±13, ±22, all-inclusive	1.5 to 3.63	0.99 μA	35 ns	1508	NanoDrive, LVC MOS	Low power
SiT1566 Super-TCXO		±3, ±5, all-inclusive (after overmold/underfills)	1.62 to 3.63	4.5 μA	2.5 ns			LVC MOS
SiT1568 Super-TCXO		±5 all-inclusive (after overmold/underfill)	1.62 to 1.98				4.5 μA	
SiT1580 TCXO								

μPOWER MHz TCXOs | Smallest size | Lower power | Drive two or more loads | Higher accuracy | Programmable for design flexibility

SiT1576 Super-TCXO	1 Hz to 2.5 MHz	±5, ±20 all inclusive	1.62 to 3.63	6.0 μA (100 kHz)	2.2 ns (100 kHz)	1508	LVC MOS	Low jitter
------------------------------	-----------------	-----------------------	--------------	------------------	------------------	------	---------	------------